

IOT BASED ICU PATIENT MONITORING SYSTEM

K.Raju¹, N. Dhana Lakshmi², P. V. N. S. S. Durga Komal³, B. Sri Hari⁴, S. Harika Devi⁵

¹Assistant Professor, Department of ECE, Ramachandra College of Engineering

^{2,3,4,5}UG Students, Department of ECE, Ramachandra College of Engineering, Eluru, A.P

E-Mail id : dhanureddy216@gmail.com

ABSTRACT

This paper presents a wearable health sensor network system for Internet of Things (IoT) connected safety and health applications. Safety and health of ICU patient are important in hospital workplace; therefore, an IoT network system which can monitor all health parameters and update through wireless. The proposed network system incorporates multiple wearable sensors to monitor environmental and physiological parameters. The wearable sensors on different subjects can communicate with each other and transmit the data to a gateway via IoT platform medical signal sensing network. In the proposed system having heart rate, temperature, vibration sensors all integrated to the parallel processing microprocessor. Health parameters re measured by sensors and give the ARDUINO module. This module analyse the data and monitor in LCD, post the same in internet of things based server. We continuously monitor, if any changes found like low heart rate, high heart rate, high temperature, patient movement IoT alerts the authorized person regarding health A smart IoT gateway is implemented to provide data processing, local web server and cloud connection. After the gateway receives the data from wearable sensors, it will forward the data to an IoT cloud for further data storage, processing and visualization.

1. INTRODUCTION

Specialists throughout the healthcare sector are increasingly leveraging the areas of concern that these developments carry in and can allow considerable improvement in and beyond the medical administrations. Similarly, the capabilities of Electronic Health apps and Health (therapeutic organizations managed by ICT) are utilized by countless regular consumers to develop, support and strengthen their healthcare network. The SMS is submitted to the specialist or to any family member in some fundamental situation. Health analysts slowly misuse the points of value these developments add to the social security market in the healthcare setting, thus creating a crucial change. Likewise, endless standard customers are helping and helping their health experts by using the M-Health (Mobile Health) applicants and EHealth. Health analysts slowly misuse the points of value these developments add to the social security market in the healthcare setting, thus creating a crucial change. Likewise, endless standard customers are helping and helping their health experts by using the M-Health (Mobile Health) programs and EHealth. A dependable and rapidly persistent portion of this corresponding technique. Structure like look (PMS). One of the biggest issues for society is the lack of social security. As the World Health Organization (WHO) parliaments demonstrate, the most elevated feature of the Medical system

is a great best thing for a person. In order to persuade and render people look, it is important to have a flash similar to the new mending machine. The system for social insurance will include stronger remedial connections for people wherever they are, in a sustainable and careful manner. Provided that such contraptions support the Internet, they boost the environment and insure that organizations and social security become continually safe and logically drawn. The whole idea of IOT remains on sensors, portion as well as remote systems that allow customers to grant and access the application / information. No place, however, is the IOT across all zones more apparent than it was in the areas of prosperity treatment. As a cliché states, 'Prosperity is money,' the movement towards greater results is phenomenally important. Therefore, it is necessary to connect to an IOT framework that provides secure and prosperous analysis. At present, the contraction of human institutions, the conventional way of coping with a technologically advanced personally driven oriented system, is being traded. As the age profile of many societies continues to increase, in addition to the increasing population of people affected by chronic diseases, including diabetes, cardiovascular disease, obesity, and so on, supporting health, both mentally and physically, is of increasing importance if independent living is to be maintained. Sensing, remote health monitoring, and, ultimately, recognizing activities of daily living have been a promising solution. From a technical perspective, the Internet of Things (IoT) is gaining a rapidly growing attention in many disciplines, especially in personalized healthcare. Meanwhile, body area sensor network (BASN) under the IoT framework has been widely applied for ubiquitous health

monitoring, for example. ECG monitoring has been commonly adopted as vital approach for diagnosing heart disease. The main contribution of this paper include the following: firstly, this paper presents a novel system, the WISE (Wearable IoT-cloud-based health monitoring system), for real-time personal health monitoring. WISE adopts the BASN (body area sensor network) framework in the support of real-time health monitoring. Several wearable sensors have been embedded, including the heartbeat, body temperature, and the blood pressure sensors. Secondly, the majority of existing wearable health monitoring systems requisite a smart phone as data processing, visualization, and transmission gateway, which will indeed impact the normal daily use of the smart phone. Whilst in WISE, data gathered from the BASN are directly transmitted to the cloud, and a lightweight wearable LCD can be embedded as an alternative solution for quick view of the real-time data. The size and composition of the world population has changed over the last couple of decades, and these trends are projected to continue. Such demographic trends have significant implications for almost all areas of the society, particularly in health and healthcare. Life expectancy has increased dramatically, especially in the more affluent nations, which is set to be celebrated and should be viewed as an opportunity for people to live longer and better. However, this requires substantial improvement in both the healthcare service and the living environment, as older people generally require more healthcare than their younger counterparts. Additionally, older people are more likely to suffer from chronic disease as part of the natural ageing process. In parallel to this demographic time bomb, the cost of healthcare provision is

increasing rapidly in all the nations across the world. The world population is increasing tremendously. The cities accommodating more population face astounding pressure of urban living. Even though the medical resources and facilities in cities are expanded daily, still the suffice level is not attained. The massive pressure towards the management of healthcare in cities has triggered the advancement in technologies to come out with the proper solutions to the booming problems. With the increased rate of medically challenged people, remote healthcare has become a part of our life. In recent years, we observe the increased interest in wearable sensors and such devices are available in market for cheaper rate for personal healthcare and activity awareness. Researchers considered implementation of such advanced devices for the medical applications for data recording, management and also to continuously monitor the patient's health. The Internet of Things offers a rising technology to attain the next level of health services [2]. It assures for the affordable, low-cost, reliable and handy devices to be carried or embedded with the patients, so that to enable seamless networking between the patients, medical devices and physicians. The sensors will record signals in a continuous manner, they are then correlated with the essential physiological parameters and communicated over the wireless network. The resulting data is stored, processed and analyzed with the existing health records [1]. Using the available data records and decision support systems, the physician can do a better prognosis so that to suggest early treatment. Even when the doctor is not available, this analysis enables the today's machines to predict the

health issues. Not only prediction, machines can also be able to come out with the medicines from the systematic study of the medicinal databases. The progressive technology will have a transformative impact in every human's life and health monitoring; it will remarkably cut down the healthcare expenses and a step ahead in the accuracy of disease predictions. In this paper, we present a idea of a service model in technological and economic views for the comfort of patients and also the open challenges in implementing IoT in real world medical field.

2. LITERATURE SURVEY

We have investigated the different examinations performed utilizing existing strategies that have been applied in the field of patient wellbeing checking. This study remembers current patterns for persistent checking frameworks and related work on the far off patient observing framework. In [2], a structure of IoT based wellbeing checking framework utilizing Raspberry Pi is proposed. In this paper, they have used Internet of Things (IoT) and distributed computing advancements. The proposed model screens the Heart Rate, Oxygen level and Blood Temperature of a patient. Distributed computing empowers tenacious capacity of information. Thus the information assembled by the wearable sensors put on a patient's body is spared in the cloud with the goal that it very well may be gotten to from anyplace over the g projection. The specialist can login to the site to get to the patient's information and produce a wellbeing report. Patients can get to the wellbeing report by signing into the site. A visit alternative is given in the site to specialist and patient

correspondence. The framework goes about as an extension among specialist and patient staying away from the separation obstruction. In country regions where satisfactory clinical offices are not accessible, it is useful and financially savvy arrangement. In [3], a wellbeing Monitoring framework utilizing Arduino is proposed thinking about the necessities of old individuals. In the maturing populace world, there is an expanded requirement for a specific wellbeing checking framework. In this unique situation, the proposed framework screens internal heat level, circulatory strain, and pulse and sends the information to specialists. These boundaries are commonly estimated during fundamental wellbeing exams as its qualities are significant indications of a patient's wellbeing condition. In the event of crisis, an alarm button is provisioned so the specialist will get a SMS when an alarm button is squeezed. Information is pushed to the web worker with the goal that the specialist and patient can see the qualities. The fundamental test watched was the delay of the older to utilize this new innovation. They should be taught to utilize new mechanical gadgets like cell phones and PCs. In [4], Wireless Bluetooth innovation with Android is investigated for the far off evaluation of wellbeing and fall identification. The framework screens the wellbeing boundaries like ECG, temperature, 'body pose', 'fall recognition' and present GPS area. Numerous synchronous Bluetooth associations are set up with an android telephone to move the gathered information. An android application investigations and procedures the information which is likewise sent to the worker utilizing the web. Information is sent to a crisis contact individual in the event of a crisis. Being a

versatile, vitality productive, lightweight and adaptable plan, it is generally appropriate for people that are at high hazard like officers guarding at high elevations, travelers, unskilled workers, and so forth. In the recent years wireless technology has increasing for the need of upholding various sectors .In these recent years IoT graped the most of industrial area specially automation and control. Biomedical is one of recent trend to provide better health care. Not only in hospitals but also the personal health caring facilities are opened by the IoT technology. So having a smart system various parameters are observed that consumes power, cost and increase efficiency .In according to this smart system, this paper is reviewed. In traditional method, doctors play an important role in health check up. For this process requires a lot of time for registration, appointment and then check up. Also reports are generated later. Due to this lengthy process working people tend to ignore the checkups or postpone it. This modern approach reduces time consumption in the process. In the recent years use of wireless technology is increasing for the need of upholding various sectors .In these recent years IoT groped the most of industrial area specially automation and control. Biomedical is one of recent trends to provide better health care. Not only in hospitals but also the personal health care facilities are opened by the IoT technology. So having a smart system, various parameters are observed that consume power, cost and increase efficiency .In accordance with this smart system, this paper is reviewed.[5] Medical scientists are trying in the field of innovation and research since many decades to get better health services and happiness in human lives. Their contribution in medical area is very important to us and cannot be neglected.

Today's automotive structures have the root ideas coming from yesterday's basics. Also Early detection of chronic diseases can be easy with this technology. [6] The body temperature, heart rate, blood pressure, respiration rate are prime parameters to diagnose the disease. This project gives temperature and heart rate values using IoT. Modern health care system introduces new technologies like wearable devices or cloud of things. It provides flexibility in terms of recording patients monitored data and send it remotely via IOT. For this connection, there is need of secure data transmission .To transmit the data with privacy is the Moto of this paper. The proposed system introduces security of health care and cloud of things .System works in two major parts viz. storage stage and data retrieving stage. In storage stage, data is stored, updated for future use. In data retrieving stage, retrieve data from cloud. The cloud server can share with authenticated user as per request. A patient with wearable devices continually updates his record every 5 or 10 min. In emergency mode, it updates for every 1min.The wearied device will send results to phone using Bluetooth connection or NFC technology. This can able to give to cloud server using GSM and 3G. At cloud server, each patient is defines with unique address. So data at cloud can authenticate the right patient and provide the required request. [7] Telemonitoring system via WBAN is evolving for the need for home based mobile health and personalized medicine. WBAN can able to collect the data acquired from sensor and record the output. This output results sent to controller wirelessly to health monitoring system. In this paper, Zigbee is used to in WBAN technology due to its guaranteed delay requirement for health telemonitoring system.

Zigbee used in the communication. [8] Afef Mdhaffar, Tarak Chaari, Kaouthar Larbi, Mohamed Jmaiel and Bernd Freisleben has explained low power WAN network to perform analysis of monitored data in health caring system. They have established WAN network for communication up to the range of 33m2 around 12 m altitude. Also they have demonstrated that power consumed by Lora WAN network is ten times less than the GPRS/3G/4G.The IOT architecture has been given for step wise working for understanding of IOT .The main purpose of Lora WAN is the energy consumption. The power consumption in idle mode for Lora WAN is 2.8mA while in GPRS is 20mA.Hardware cost in Lora WAN is 10doller while in GPRS is 50 dollar. Maximum data rate in Lora WAN is 50kbps (uplink), 50 kbps downlink while in GPRS is 86.5 kbps (uplink, 14kbps (downlink).These results gives the overall efficiency of Lora WAN in the demonstration of IOT for health monitoring system. [9] Mohammad M. Masud, Mohamed Adel Serhani, and Alramzana Nujum Navaz had given the measurement of ECG signals at various intervals and at different situations. They have considered energy aware, limited computing resources and lose network continuity challenges .For these challenges; mathematical model has been developed to execute each task sequentially. There are three approaches designed to work out the process .One is mobile based monitoring approach, data mining and third is machine learning approach [10] Ayush Bansal , Sunil Kumar, Anurag Bajpai, Vijay N. Tiwari, Mithun Nayak, Shankar Venkatesan, Rangavittal Narayanan focuses on development of a system which is capable of detecting critical cardiac events. Using an advanced remote monitoring system to

detect symptoms which lead to fatal cardiac events [11] Hamid Al-Hamadi and Ing-Ray Chen gives trust based health IOT protocol that considers risk classification, reliability trust, and loss of health probability as design dimensions for decision making. Comparative analysis of trust based protocol and baseline protocols to check feasibility.[12] Muthuraman Thangaraj Pichaiah Punitha Ponmalar Subramanian Anuradha ."Digital hospital" term is introduced for hospital management. It enables automatic electronic medical records in standard. Also discusses with the implemented real worldscenario of smart autonomous hospital management with IOT. [13]

3. EXISTING SYSTEM

In existing system of health monitoring system many sensors are used to measure the health parameters temperature, body motion, pulse rate all are measure and displays in LCD only. In existing model we don't have data transfer through longer distance using any wireless communication. To secure the patient health the proposed model implemented with IOT setup automatically sends alerts to doctor and relative in case of emergency.

4. PROPOSED SYSTEM

In the proposed system of health monitoring system we used temperature sensor, heart beat sensor and humidity sensor for monitoring the human body health parameters and display in LCD and IOT server. If the heart rate fluctuations mean if we got low BP or HIGH BP then buzzer module automatically alerts and same thing will update in server.

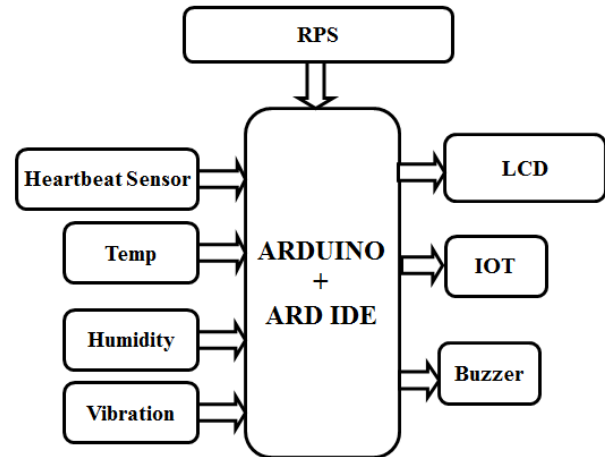

Fig.1. Proposed block diagram

WORKING MODEL:

This methodology is intended to build a structured remote observation system for well being. The goal is to track the patient's body's temperature and heart rate that the NRF innovation specialist will be faced with. The care services in medical centers are consistent with the assessment of the well being of the patients. The body of the patient is continuously monitored for temperature and pulse and registered. This interface is simple, illustrating the usage of ESP8266 and Arduino IoT Patient Safety Monitoring Program. Temperature sensors Pulse and LM35 monitor separately BPM and Ambient Temperature. The Arduino designs the application and shows an LCD panel with 16 * 2. Starts sending the data to the IoT application server via WLAN ESP8266 unit partners with both the WiFi. Thing speaks is the IoT server used in this. Finally, data from anywhere in the world can only be verified by identifying the channel Thing speak. Hardware modules used in this proposed system is explained in below.

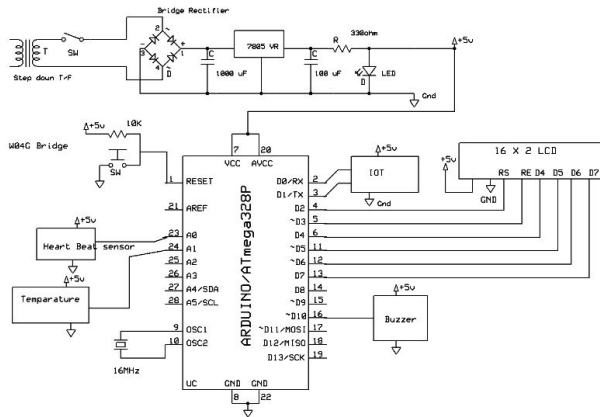

Fig.2. Proposed Circuit diagram

5. RESULTS

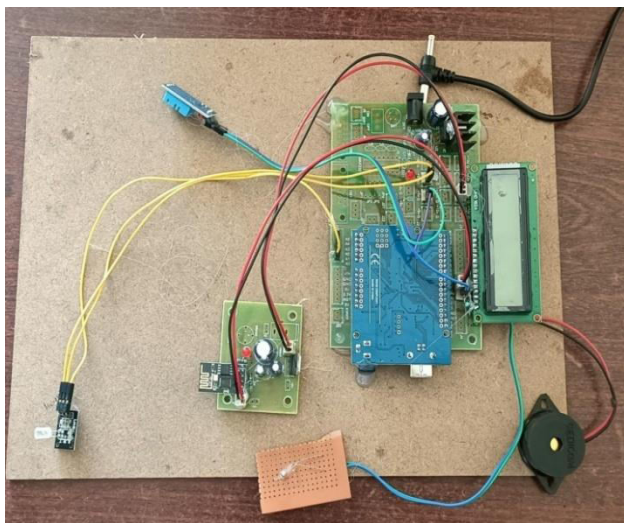

Fig.3. Proposed Output model

Here the circuit is powered ON by giving the regulated power supply of 12v which is converted to 5v dc current. The LED is the indication for 5v current so, if there is 5v current then the LED automatically glows. The generated 5v dc current passes to every hardware component in the circuit. When the vibration sensor acts as a switch in the circuit which gives the fall alert to the doctor. Which takes the data from satellite and gives to the controller. For the output we are using piezo

electric buzzer and IOT server. The IOT server sends the information to the website through WI-FI network. For every 5 seconds the information has been changing in the website. Hence the buzzer and IOT server are output modules



Fig.4. LCD Output

For such critical conditions the doctors need to have an all-time update about patient’s health related parameters like their heartbeat, temperature, humidity. In this way IOT based Patient Health Monitoring System will helps in monitoring ICU Patient’s without any intervention. The output from sensor and amplifier circuit was connected to the Arduino. The observed output signal was periodic AC signal with amplitude varying from peak-to-peak according to person. A sinusoidal signal and the output from server were fed to Arduino and the counted parameters will sent via WIFI module.

Page 1 of 1

S.No	Temperature	Humidity	Heart Beat	Vib	Date
1	30	86	0	OFF	2023-01-24 15:11:15
2	30	85	0	ON	2023-01-24 15:10:55
3	30	85	0	OFF	2023-01-24 15:10:35
4	30	88	0	OFF	2023-01-24 15:03:29
5	29	86	70	OFF	2023-01-24 15:03:09
6	29	84	74	OFF	2023-01-24 15:02:49
7	29	49	73	ON	2023-01-24 15:02:09
8	28	45	78	ON	2023-01-22 16:47:26
9	26	50	0	ON	2023-01-22 11:56:35

Fig.5. Web server Output

Table.1 Results comparison Table

Parameter	Existing Model	Proposed Model
Microcontroller	8051	Arduino
Speed	Low	High
Complexity	High	Low
Efficiency	LOW	HIGH

6. CONCLUSION

We designed and implemented Arduino Based E – Health System over Internet of Things with integrating of all input modules like temperature, humidity, position motions, heart rate monitoring sensors, output modules LCD, buzzer and wireless communication system called internet of things through Arduino processor. In this proposed system, the various health parameters such as pulse rate, temperature, angle movement of fingers were monitored and recorded in the IOT platform. The values of these parameters were analyzed and alerted in this the proposed system. In future we will add some other sensors which enhance the health monitoring system like gluecometer and body fat device measurement we an add.

REFERENCES

1. Fezari M., Bousbia-Salah M., Bedda M., Microcontroller Based Heart Rate Monitor, The International Arab Journal of Information

Technology, Vol. 5, No. 4, October 2008, pp.153-157

2. Lee H., Park S., and Woo E., Remote Patient Monitoring Through the World-Wide Web, in Proceedings of the 19th International Conference of IEEE, Chicago, IL, USA, pp. 928-931, 1997

3. Pulse checking and heart assault location ,Mamidimanisha, Katakanneraja, International Journal of Innovations in Engineering and Technology (IJIET)

4. Stephanie B. Baker, Wei Xiang, Ian Atkinson. Internet of Things for Smart Healthcare: Technologies, Challenges, and Opportunities 2015

5. Ani R, Krishna and AnjuIoT Based Patient Monitoring and Diagnostic Prediction Tool using Ensemble Classifier on 2017.

6. M. H. Aref, A. A. El-shinnawi, and A. A. Sharawi, "Wireless Nurse Call System in Medical Institutions," vol. 6, no. 2, pp. 40–45, 2018

7. Matthew D'Souza, Montserrat Ros, Adam Postula, "Remote Medical Information System Network for Patient ECG Monitoring" Digital System.

8. Lee H., Park S., and Woo E., Remote Patient Monitoring Through the World-Wide Web, in Proceedings of the 19th International Conference of IEEE, Chicago, IL, USA, pp. 928-931, 1997