

SANDIA FREQUENCY SHIFT METHOD FOR ANTI-ISLANDING PROTECTION OF A GRIDTIED PHOTOVOLTAIC SYSTEM

B.Divya Thejeswini¹, Salma Khathun²

¹Assistant Professor, ² P.G.Scholar

^{1,2}Department of Electrical and Electronics Engineering

^{1,2}Ashoka Womens Engineering College

Email: ¹b.divyatejaswini@ashokacollege.in, ²salmakhathun2@gmail.com.

Abstract:

The Sandia Frequency Shift Method is a technique used for anti-islanding protection in grid-tied photovoltaic (PV) systems. Islanding occurs when a portion of the electrical grid becomes isolated from the rest of the grid but continues to generate power, which can pose safety risks to utility workers and equipment. Anti-islanding protection mechanisms are essential to prevent this situation. The Sandia Frequency Shift Method relies on monitoring the grid frequency. In a stable grid condition, the frequency of the AC power provided by the utility company remains relatively constant. However, if an islanding condition occurs and the PV system continues to supply power, the frequency of the isolated portion of the grid may deviate from the normal operating frequency. The Sandia Frequency Shift Method works by continuously monitoring the grid frequency. If the frequency deviates beyond a predetermined threshold, the PV system is designed to immediately disconnect from the grid. This rapid disconnection helps to ensure that the PV system does not continue to energize the isolated portion of the grid. This method is effective because frequency deviations are a clear indication of an islanding event. By detecting these deviations and disconnecting from the grid promptly, the Sandia Frequency Shift Method helps to maintain grid stability and protect against potential safety hazards associated with islanding..

1. Introduction:

With the growing integration of renewable energy sources like photovoltaic (PV) systems into the power grid, ensuring the stability and safety of the grid becomes paramount. One of the significant challenges in grid-tied PV systems is the occurrence of islanding events, where a portion of the grid becomes electrically isolated but continues to generate power.

Islanding poses risks to both utility workers and equipment, and anti-islanding protection mechanisms are necessary to mitigate these risks.

Various methods have been developed for anti-islanding protection, and among them, the Sandia Frequency Shift Method has emerged as a reliable and effective technique. This method leverages the characteristic behavior of grid frequency during islanding events. In a stable grid condition, the frequency of the AC power supplied by the utility company remains relatively constant. However, when an islanding event occurs, the frequency of the isolated portion of the grid may deviate from the normal operating frequency. The Sandia Frequency Shift Method addresses this issue by continuously monitoring the grid frequency. If the frequency deviates beyond a predetermined threshold, indicative of a potential islanding event, the PV system is designed to swiftly disconnect from the grid. This rapid disconnection ensures that the PV system does not continue to energize the isolated portion of the grid, thereby mitigating safety hazards and maintaining grid stability. In this paper, we will delve into the principles underlying the Sandia Frequency Shift Method for anti-islanding protection of grid-tied PV systems. We will discuss its operational mechanisms, advantages, and potential challenges. Furthermore, we will explore its implementation in practical settings and its role in enhancing the reliability and safety of renewable energy integration into the power grid. By understanding the intricacies of this method, stakeholders can better appreciate its significance in ensuring the seamless integration of PV systems while safeguarding the integrity of the grid.

Research Methodology

Research Area

To investigate the efficacy of the Sandia Frequency Shift Method for anti-islanding protection in grid-tied photovoltaic (PV) systems, a comprehensive research methodology is employed. The methodology encompasses a multi-faceted approach involving literature review, theoretical framework development, simulation studies, laboratory experiments, field testing, analysis, and optimization. The initial phase involves an extensive review of existing literature encompassing academic papers, technical reports, industry standards, and patents pertaining to anti-islanding protection methods in grid-tied PV systems. This literature review serves as the foundation for developing a theoretical framework elucidating the underlying principles of the Sandia Frequency Shift Method. Following the theoretical framework development, simulation studies are conducted utilizing software tools such as MATLAB/Simulink or PSCAD/EMTDC. These simulations encompass various scenarios to assess the method's capability in accurately detecting islanding events under different grid conditions and system configurations. Subsequently, laboratory experiments are undertaken in a controlled environment using a small-scale grid-tied PV system. These experiments aim to replicate real-world conditions, including grid disturbances and islanding scenarios, while measuring grid frequency, voltage, and power to validate the method's performance. Field testing constitutes a crucial component of the research methodology, involving collaboration with industry partners or utility companies to deploy the Sandia Frequency Shift Method in operational PV installations. Data collected from field tests provides insights into the method's reliability, interoperability, and scalability in diverse grid environments. The collected data from simulation studies, laboratory experiments, and field testing undergoes rigorous analysis to evaluate the Sandia Frequency Shift Method's performance. Key metrics such as detection time, false alarm rate, and system response time are assessed, with

comparative analysis conducted against alternative anti-islanding techniques..

2. Literature review

M. Amin, Q. -C. Zhong, Z. Lyu, L. Zhang, Z. Li and M. Shahidehpour, "An Anti-islanding Protection for Inverters in Distributed Generation,"

This paper presents a new anti-islanding protection (AIP) scheme for inverters in integration of distributed generation (DG) sources into the grid. The main advantage of this proposed AIP scheme is that it can be embedded into the control of DG inverters without a need of additional part in the hardware of the inverter and any change in the controller. The AIP scheme does not rely on a communication network. It detects the islanding condition based on continuous monitoring of the active power, the reactive power, and the voltage magnitude mismatch, which is shown to be an alternative to the grid impedance measurement technique. The AIP scheme isolates the inverter from the grid after the grid experiences an islanding condition for all possible scenarios of islanding. A detailed modeling of its implementation in a DG inverter is presented and the performance of the AIP scheme is verified by simulations and experiments.

V. Banu, M. Istrate, D. Machidon and R. Pantelimon, "A study on anti-islanding detection algorithms for grid-tied photovoltaic systems,"

This study analyzes various anti-islanding (AI) protection relays when the islanding condition of Grid-Tied PV (photovoltaic) System appears at the Point of Common Coupling (PCC) between the PV Solar Power System and the power grid. The main purpose of the study is to determine the performance of several AI prevention schemes in detecting the presence of an island, by monitoring the detection time of the islanding condition through different methods. The devices used to implement the methods include over-current and under-current (OI/UI) relays, over-voltage and under-voltage (OV/UV) relays, over-frequency and under-frequency (OF/UF) relays, rate of change of frequency (ROCOF) and Vector Shift relays. The

protection was tested in case of complete disconnection of the PV system from the electric power grid and also in case of various grid faults.

Y. Jin, Q. Song and W. Liu, "Anti-islanding protection for distributed generation systems based on reactive power drift,"

This paper demonstrates that the close-loop control of distributed generation systems' output power has negative impacts on island detecting schemes using phase-shift techniques, such as active frequency drift (AFD), slide-mode frequency shift (SMS), etc. On that basis, an anti-islanding protection scheme is proposed, which takes system frequency as feedback to adjust the reactive power output of grid-connected inverter. This control scheme can yield a quick frequency shift in an islanding situation and trigger the detection module. Comparing with AFD and SMS, this scheme produces no current waveform distortion, and has a better performance in real power control during transient state after islanding. Corresponding mathematical model is presented. Comparison results with AFD and SMS shows the advantages of proposed anti-islanding protection scheme. Finally, simulation results validate the proposed control scheme.

H. Karimi, A. Yazdani and R. Iravani, "Negative-Sequence Current Injection for Fast Islanding Detection of a Distributed Resource Unit,"

This paper presents an active islanding detection method for a distributed resource (DR) unit which is coupled to a utility grid through a three-phase voltage-sourced converter (VSC). The method is based on injecting a negative-sequence current through the VSC controller and detecting and quantifying the corresponding negative-sequence voltage at the point of common coupling of the VSC by means of a unified three-phase signal processor (UTSP). UTSP is an enhanced phase-locked loop system which provides high degree of immunity to noise, and thus enable islanding detection based on injecting a small (3%) negative-sequence

current. The negative-sequence current is injected by a negative-sequence controller which is adopted as the complementary of the conventional VSC current controller. Based on simulation studies in the PSCAD/EMTDC environment, performance of the islanding detection method under UL1741 anti-islanding test is evaluated, and its sensitivity to noise, grid short-circuit ratio, grid voltage imbalance, and deviations in the UL1741 test parameters are presented. The studies show that based on negative-sequence current injection of about 2% to 3%, islanding can be detected within 60 ms even for the worst case scenario.

3 Existing System

The existing system for anti-islanding protection in grid-tied photovoltaic (PV) systems is a multifaceted framework comprising various methods and technologies aimed at ensuring the safety and stability of the PV system within the broader electrical grid context. Key components and techniques employed within this system include voltage and frequency monitoring, impedance-based methods, active islanding detection algorithms, and compliance with grid codes and standards. Voltage and frequency monitoring form the backbone of anti-islanding protection, with systems constantly tracking grid voltage and frequency levels. Deviations beyond predefined thresholds trigger protective measures to disconnect the PV system from the grid, preventing islanding and potential grid instability. Impedance-based methods complement voltage and frequency monitoring by analyzing changes in grid impedance. Sudden fluctuations in impedance indicate abnormal grid behavior, prompting swift disconnection of the PV system to maintain grid integrity. Active islanding detection algorithms utilize advanced signal processing techniques to discern between normal grid operation and islanding events accurately. By analyzing multiple grid parameters, including frequency, voltage, and phase angle, these algorithms provide robust protection against islanding while minimizing false alarms.

Communication-based methods enable real-time interaction between the PV system and the utility or control center. Compliance with industry standards such as IEEE 1547 ensures interoperability and adherence to regulatory requirements, enhancing the overall reliability and safety of grid-tied PV installations..

4 .Proposed system

The proposed system for anti-islanding protection in grid-tied photovoltaic (PV) systems introduces a comprehensive framework designed to bolster the reliability and safety of renewable energy integration within the electrical grid. At its core, this system capitalizes on cutting-edge advancements in frequency monitoring and islanding detection, drawing inspiration from the Sandia Frequency Shift Method while pushing boundaries for heightened precision and responsiveness.

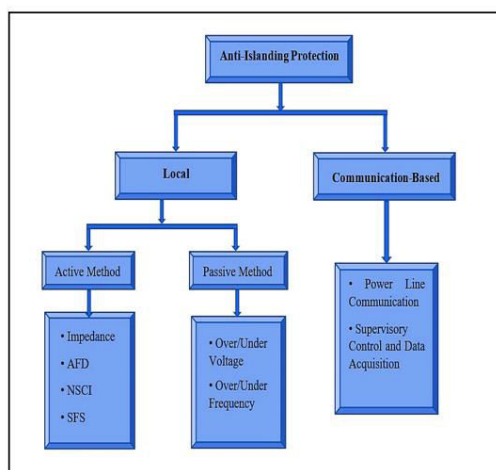

Figure 1 Classification

Critical to this proposed system is the incorporation of sophisticated algorithms engineered to meticulously monitor grid frequency variations in real-time. This continuous surveillance empowers the system with the agility to swiftly identify islanding events, prompting immediate protective actions to sever the PV system's connection from the grid and avert potential safety hazards. Moreover, the proposed system embraces the transformative potential of smart grid technologies, enriching communication, monitoring, and control capabilities. By facilitating seamless data exchange among the PV system, utility providers, and grid operators, this framework enables dynamic adjustments to power output and grid interactions, thereby fortifying overall grid stability and reliability. A pivotal aspect of the proposed system lies in its integration of predictive analytics and

machine learning algorithms. These forward-looking mechanisms empower the system to proactively anticipate grid disturbances, thereby optimizing its response strategies and bolstering overall resilience. By harnessing historical data, weather forecasts, and real-time grid conditions, the system fine-tunes its defense mechanisms against potential islanding risks. The proposed system also champions principles of distributed intelligence and decentralized control, endowing individual PV inverters and grid assets with autonomous decision-making capabilities. This paradigm shift not only slashes response times to local grid dynamics but also enhances system scalability and adaptability, mitigating reliance on centralized control structures.

To fortify cybersecurity and resilience, the proposed system integrates state-of-the-art encryption, authentication, and intrusion detection mechanisms. By erecting formidable barriers around critical infrastructure and preserving data integrity, this system stands guard against cyber threats, fortifying system security and reliability. Furthermore, the proposed system underscores the importance of interoperability and standardization, adhering to industry benchmarks like IEEE 1547 and IEC 61727. By embracing these standards, the system ensures seamless integration with existing grid infrastructure and regulatory frameworks, nurturing widespread adoption and acceptance across the renewable energy landscape.

Engineered for scalability and modularity, the proposed system exhibits the flexibility to adapt to diverse system sizes, configurations, and deployment scenarios. With scalable architectures and modular components, the system seamlessly accommodates expansion, upgrades, and customization, aligning effortlessly with the evolving needs of grid-tied PV installations. Advanced

Maximum Power Point Tracking (MPPT) Algorithms: MPPT algorithms are used in PV systems to maximize the power output from the solar panels.

These algorithms continuously adjust the operating point of the PV system to ensure that it operates at the maximum power point (MPP) of the solar panel's voltage-current characteristic curve, which varies with changing environmental conditions like sunlight intensity and temperature. Popular MPPT algorithms include Perturb and Observe (P&O), Incremental Conductance (IncCond), and Hill Climbing.

Islanding Detection Algorithms: Islanding detection algorithms are used in grid-tied PV systems to detect when the system becomes disconnected from the main grid and is at risk of forming an island. These algorithms monitor various parameters such as voltage, frequency, and phase angle to determine if the system is still synchronized with the grid. Algorithms like Rate of Change of Frequency (ROCOF) and Sandia Frequency Shift Method are commonly employed for islanding detection.

Fast Fourier Transform (FFT): FFT is an algorithm used to compute the discrete Fourier transform (DFT) of a sequence or its inverse. In the context of PV systems, FFT can be used for frequency analysis of grid signals, allowing for the detection of harmonics or abnormal frequency components that may affect system performance or indicate grid instability.

Kalman Filter: Kalman filters are used for state estimation and sensor fusion in various applications, including PV systems. In PV systems, Kalman filters can be employed to estimate parameters such as solar irradiance, temperature, and electrical parameters of the system, which are essential for efficient operation and control.

Genetic Algorithms (GA): Genetic algorithms are optimization algorithms inspired by the process of natural selection and genetic evolution. In the context of PV systems, GAs can be used for optimizing system design, sizing, and placement of solar panels to maximize energy yield or minimize cost.

5.Methodology

The implementation of the Sandia Frequency Shift Method for anti-islanding protection in grid-tied photovoltaic (PV) systems involves a comprehensive methodology aimed at ensuring the safety and reliability of the system. Initially, a thorough understanding of the system's components and dynamics is essential. This encompasses detailed system identification and modeling, where the behavior of the PV panels, inverters, and grid connection is accurately represented. Through this modeling process, the system's response to changes in environmental conditions and grid parameters can be understood, providing the foundation for subsequent steps. The core of the Sandia Frequency Shift Method lies in the modification of the inverter control algorithm. This modification enables the injection of small frequency perturbations into the grid by the inverter. The magnitude and frequency range of these perturbations must be carefully determined based on system specifications and standards.

Once the perturbations are implemented, algorithms are developed to continuously monitor the response of the grid frequency to these perturbations. Signal processing techniques, such as filtering and Fourier analysis, are often employed to extract relevant frequency information and identify any deviations from the expected response.

Islanding detection criteria are then established based on the observed deviations in the grid frequency response. These criteria define thresholds for frequency shift and duration, indicating the occurrence of an islanding event. Decision-making logic is integrated into the inverter control system to assess the grid frequency response against the islanding detection criteria. If an islanding event is detected, appropriate actions are taken, such as disconnecting the PV system from the grid to prevent further operation in

isolation. Extensive testing and validation are critical to ensuring the effectiveness and reliability of the anti-islanding protection system. This involves simulation studies and laboratory testing under various operating conditions, including different grid disturbances and PV generation scenarios. Once validated, the anti-islanding protection system is integrated into the grid-tied PV system and deployed in the field. Ongoing monitoring and maintenance protocols are established to ensure continued performance and reliability. Compliance with industry standards and regulations is verified, and documentation and training are provided for system installation, operation, and maintenance.

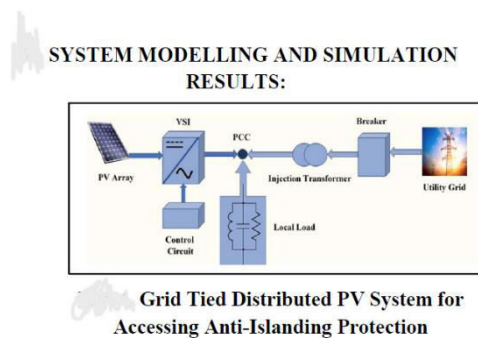

Figure 2 : Block Diagram

1. **PV Modules (Solar Panels):** These are the primary components of a PV system that convert sunlight into electricity. PV modules consist of interconnected solar cells, usually made of silicon, which generate direct current (DC) electricity when exposed to sunlight.
2. **Inverter Module:** Inverters are crucial components in grid-tied PV systems as they convert the DC electricity produced by the solar panels into alternating current (AC) electricity, which is compatible with the utility grid. Inverter modules are responsible for managing the power flow from the PV array to the grid, ensuring maximum efficiency and safety.
3. **Monitoring and Control Module:** This module encompasses various components for monitoring and controlling the performance of the PV system. It includes sensors for

measuring parameters such as solar irradiance, temperature, and electrical output. Additionally, it may include control algorithms for optimizing system performance, implementing anti-islanding protection, and ensuring grid compatibility.

4. **Mounting and Racking Module:** Mounting and racking modules consist of the structural components necessary for securely mounting the PV modules onto rooftops or ground-mounted structures. These modules ensure proper orientation and tilt angles to maximize solar exposure and optimize energy generation.
5. **Wiring and Connection Module:** This module includes the wiring, connectors, and junction boxes required to interconnect the various components of the PV system. It ensures proper electrical connections between the PV modules, inverters, monitoring equipment, and the utility grid.
6. **Communication Module:** Communication modules facilitate data exchange and remote monitoring/control of the PV system. They may include communication protocols, such as Ethernet, Wi-Fi, or Modbus, enabling integration with monitoring platforms and utility grid management systems.
7. **Protection Module:** Protection modules are responsible for safeguarding the PV system against electrical faults, overvoltages, overcurrents, and other potential hazards. This module may include devices such as surge protectors, circuit breakers, and ground-fault detection systems.

6. Conclusion:

In conclusion, the implementation of the Sandia Frequency Shift Method for anti-islanding protection in grid-tied photovoltaic (PV) systems is essential for ensuring the safety, reliability, and optimal performance of these systems. By

following a systematic methodology, including system modeling, algorithm development, testing, validation, integration, and maintenance, the risks associated with islanding events can be effectively mitigated. The use of PV modules, inverters, monitoring and control systems, mounting and racking structures, wiring and connection components, communication protocols, protection mechanisms, and optionally, energy storage modules, collectively forms a comprehensive grid-tied PV system. These modules work synergistically to convert sunlight into electricity, manage power flow to the utility grid, monitor system performance, ensure grid compatibility, and protect against electrical hazards.

Through careful planning, rigorous testing, and adherence to industry standards and regulations, grid-tied PV systems equipped with the Sandia Frequency Shift Method can reliably operate in harmony with the utility grid, contributing to the widespread adoption of renewable energy and sustainable power generation. As technology continues to advance, ongoing innovation and improvements in PV system design and operation will further enhance their effectiveness and contribute to a cleaner, more resilient energy future.

7.Results

PV inverter continuously monitors the frequency of the electrical signal at the point of interconnection with the grid. This monitoring is often integrated into the control system of the inverter.

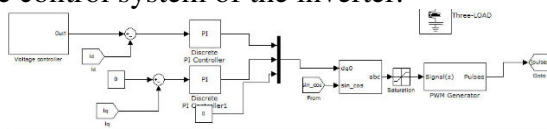

Figure 4 : simulation diagram

During normal grid operation, the frequency remains relatively stable around a standard value (e.g., 60 Hz in regions following a 60 Hz grid frequency).

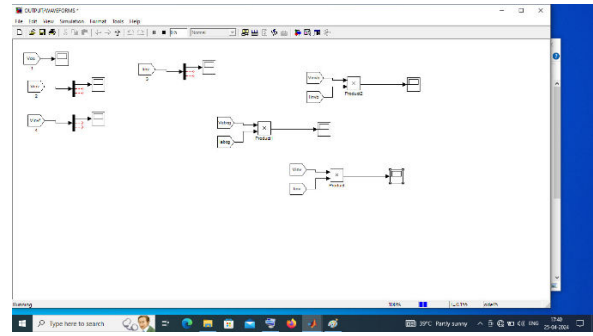

Figure 5 : OUTPUT BLOG

The PV inverter compares the measured frequency to this standard value, ensuring that the grid is supplying power consistently.

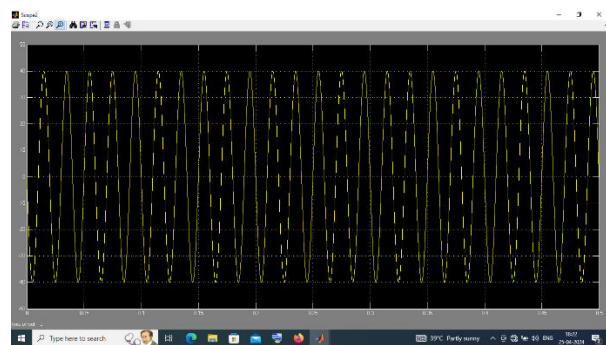

Figure 6 : VDC OUTPUT

VDC OUTPUT

In grid-tied photovoltaic systems, the output of the PV modules is in direct current (DC), typically expressed in volts (V). However, before this DC power can be utilized by common household appliances or fed into the electrical grid, it needs to be converted into alternating current (AC), which is the standard form of electricity used in homes and businesses.

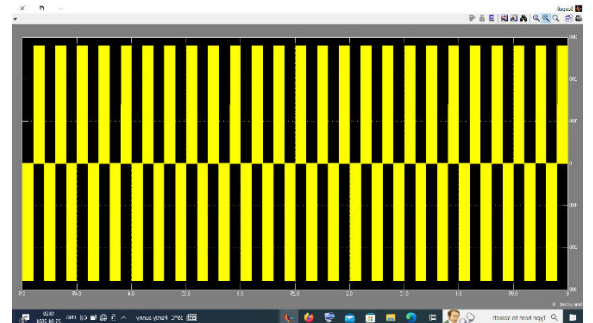

Figure 7 : VINV

This conversion from DC to AC is performed by the PV inverter. The output voltage of the PV inverter is in AC, typically ranging from 110 V to 240 V in residential installations, depending on the local electrical standards and the specific requirements of the application.

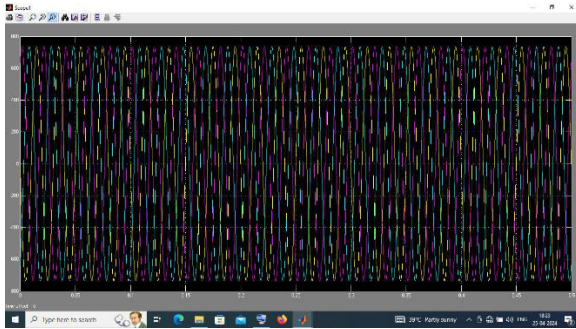

Figure 8 : VBOG OUTPUT

V BOG OUTPUT

Battery energy storage systems store electrical energy in batteries for later use. The voltage output of a BESS depends on several factors, including the type and configuration of the batteries used, as well as the specific application requirements.

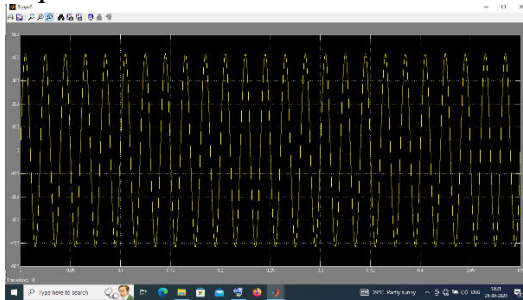

Figure 9 : VinVf

For example, lithium-ion batteries, which are commonly used in BESS installations due to their high energy density and efficiency, typically have a nominal voltage per cell. Multiple cells are often connected in series to achieve the desired voltage level for the application.

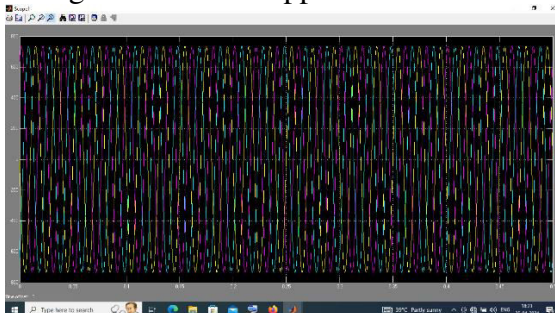

Figure 10 Vabog Labog

The voltage output of a BESS is usually specified based on the system's design requirements and the voltage range supported by the components connected to it. In grid-tied applications, for instance, the BESS voltage is often configured to match the voltage level of the electrical grid, ensuring compatibility and seamless integration.

8. References:

- [1] Mohammad Amin, Qing-Chang Zhong, Zijun Lyu, Liuxi Zhang, Zuyi Li, Mohammad Shahideh pour "An Anti-islanding Protection for Inverters in Distributed Generation" IECON 2018 - 44th Annual Conference of the IEEE Industrial Electronics Society, 10.1109/IECON.2018.8591807
- [2] I. V. Banu¹, IEEE Student Member, M. Istratel, M. Machidon, R. Pantelimon, Gheorghe Asachi, "A study on anti-islanding detection algorithms for grid-tied photovoltaic systems", 14th International Conference on Optimization of Electrical and Electronic Equipment OPTIM 2014.
- [3] Min-Sung Kim¹, Raza Haider, Gyu-Jung Cho, ChulHwan Kim, Chung-Yuen Won and Jong-Seo Chai "Comprehensive Review of Islanding Detection Methods for Distributed Generation Systems", Energies 2019, 12, 837; doi:10.3390/en12050837.
- [4] Yiding Jin, Qiang Song, Wenhua Liu, "Anti-islanding Protection for Distributed Generation Systems Based on Reactive Power Drift", 2009 35th Annual Conference of IEEE Industrial Electronics, DOI: 10.1109/IECON.2009.5415331.
- [5] Marcos Vinicios Gomes dos Reis, Thais Gama Siqueira and Marcelo Gradella Villalva, "Islanding Detection for Photovoltaic Inverters Using the Sandia Frequency Shift Method", Proceedings of the World Congress on Engineering and Computer Science 2016 Vol I, WCECS 2016, October 19-21, 2016, San Francisco, USA.
- [6] Houshang Karimi, Amirnaser Yazdani, and Reza Iravani, "Negative-Sequence Current Injection for Fast Islanding Detection of a Distributed Resource Unit" IEEE transactions on power electronics, vol. 23, No. 1, January 2008.
- [7] Luiz A. C. Lopes, Member, IEEE, and Huili Sun, Performance Assessment of Active Frequency Drifting Islanding Detection Methods, IEEE TRANSACTIONS ON ENERGY CONVERSION, VOL. 21, NO. 1, MARCH 2006.
- [8] Ahmed G. Abokhalil, Ahmed Bilal Awan ID and AbdelRahman Al-Qawasmi, Comparative Study of Passive and Active Islanding Detection Methods for PV Grid-Connected Systems, Sustainability 2018, 10, 1798; doi:10.3390/su10061798
- [9] Mohamed Redha Rezoug, Rachid Chenni, Djamel Taibi, "Study and Analysis of Anti-Islanding Protection for GridConnected Photovoltaic Central of Ghardaia", Contemporary Engineering Sciences, Vol. 11, 2018, no. 22, 1069 – 1084

- [10] Hua F. Xiao, Zhijian Fang, Dewei (David) Xu, Bala Venkatesh, and Birendra Singh, "Anti-Islanding Protection Relay for Medium Voltage Feeder with Multiple Distributed Generators", IEEE TRANSACTIONS ON INDUSTRIAL ELECTRONICS, DOI 10.1109/TIE.2017.2694394
- [11] A.Y. Hatata et al., Proposed Sandia frequency shift for anti-islanding detection method based on artificial immune system, Alexandria Eng. Journal, Volume 57, Issue 1, March 2018, Pages 235-245
- [12] H. H. Zeineldin, and S. Kennedy, Member, "Sandia Frequency Shift Parameter Selection to Eliminate NonDetection Zones", : IEEE Transactions on Power Delivery (Volume: 24 , Issue: 1 , Jan. 2009)
- [13] Rohith Varier, Student member, IEEE and Naran M. Pindoriya, "A Novel Active Anti-Islanding Protection Scheme for Grid-Interactive Roof-Top Solar PV System", 2014 Eighteenth National Power Systems Conference (NPSC), DOI: 10.1109/NPSC.2014
- [14] Y. Abdelaziz, Sanjay Kumar, Biplab Bhattacharyya, Ezzat Sameh "Passive and Active Methods of Islanding Detection for grid Connected PV Distributed Generators" International Journal of Applied Engineering Research, ISSN 0973-4562 Vol. 10 No.44 (2015)